

POWER/HALF RACK COMBO DP

Take two premium rack series and combine them for the ultimate in performance, safety and capacity with Dynamic's Ultra Pro Power/Half Rack Combo featuring dual post plate storage. The functionality of the half rack with the added safety and capability of the power rack all in one. Also available with single storage posts offering 10 bumper plate storage pegs.

Features:

- 2-Inch Adjustable Anchor Point Increments
- Laser-Cut Numbering
- U-Base Design for Greater Structural Integrity and Storage Options
- (4) NOTCH-LOCK J-Cups, (2) 28" Safety Arms and (2) 34" Safety Arms
- (2) Multi-Grip Chin Station
- (4) Barbell Storage
- (20) Plate Storage Pegs
- Intensive Multi-Stage Pretreatment Process for Long-Lasting Powder-Coat Finish

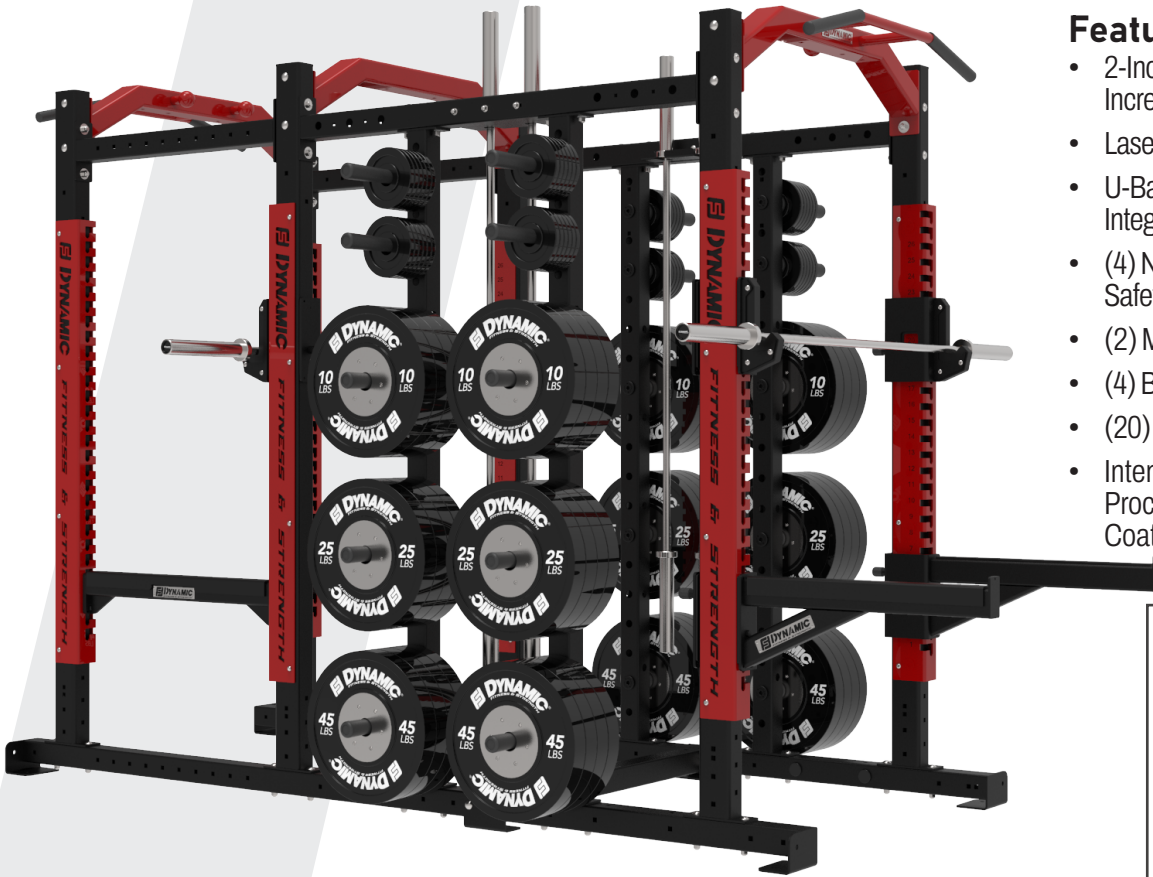

700107
features powder-coated upright wraps

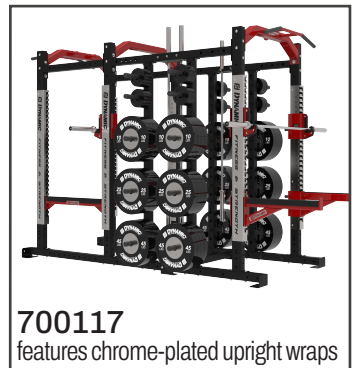

700117
features chrome-plated upright wraps

Bumper plates and Barbells shown for display purposes only. Not included with unit.



A full line of add-on equipment:

MORE STRENGTH PER SQUARE FOOT™

Increase the functionality of your rack with these and more Ultra Pro accessories & attachments.

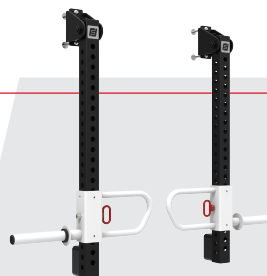

Athletic Training Arms

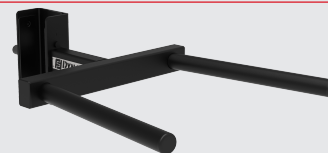

Dip Station



Split Squat Roller

Landmine

700107/700117

Ultra Pro™ Series

POWER/HALF RACK COMBO DP

Specifications:

FRAME: 5" X 3" 7-Gauge Structural Steel Tubing

WEIGHT: 1276 LBS

DIMENSIONS: 75" W x 95" H x 143" L

