



Bump Stop Allows  
for Vertical Storage

718065SS

Specialty Bench Line

# PRO LADDER BENCH W/SPOTTER

Elevate your fitness with the XL Ladder Bench from Dynamic Fitness & Strength. It features a generous 12" pad, adjustable back angles (0-85°), and a spotter platform for safety. Its mobility and stability are ensured with a rolling base and protective rubber feet, and you can customize it with various color pad options. With our intensive pretreatment and powder-coat finish, this bench is built to last, making it the ultimate choice for a versatile, stylish, and durable workout experience.

### Features:

- Extra-wide 12" Pad
- Adjustable Back Pad Angles, 0-85°
- Spotter Platform
- Protective Rubber Feet
- Rolling Base for Easy Transport
  - Custom Color Pad and Custom Printed Slip Cover Options Also Available
  - Intensive Multi-Stage Pretreatment Process for Long-Lasting Powder-Coat Finish

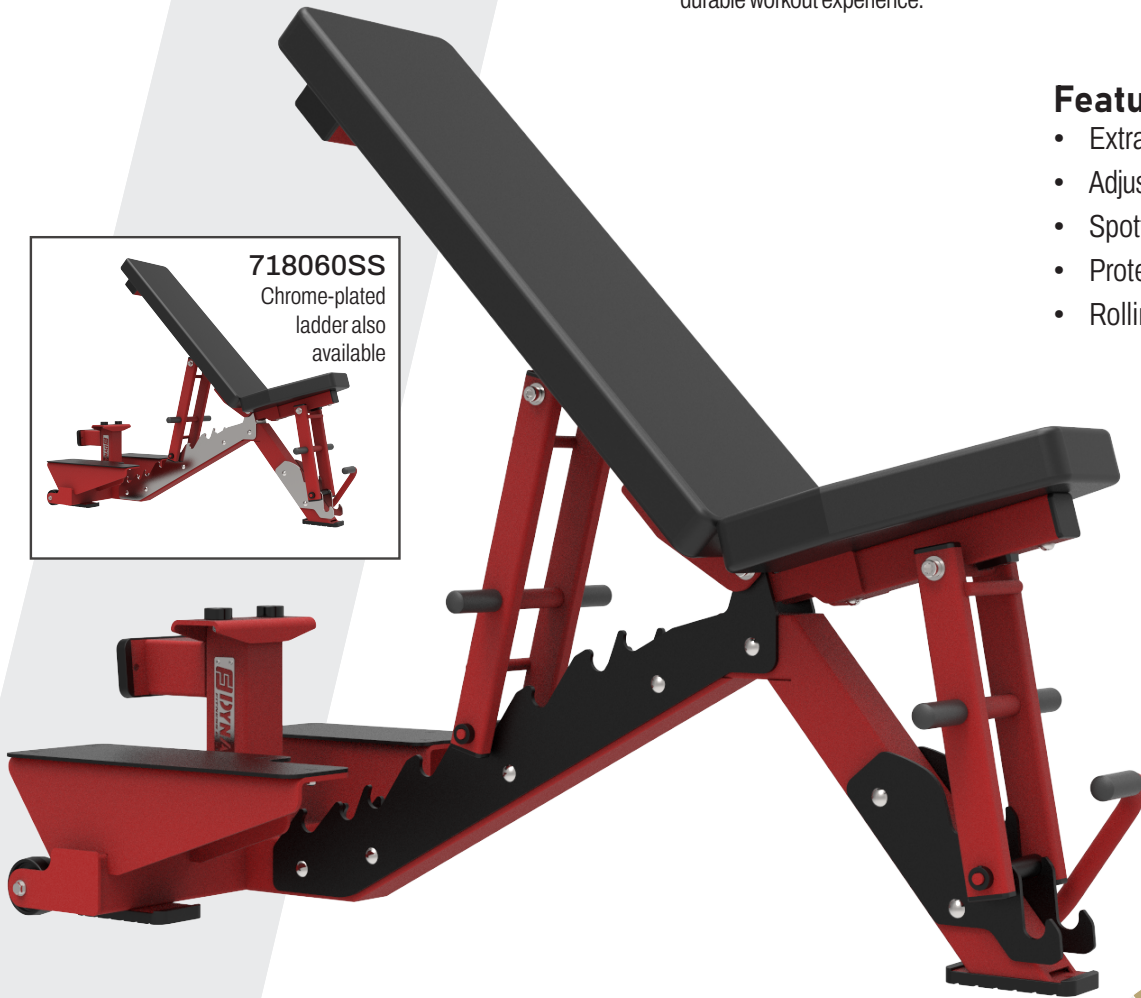

A full line of benches

MORE STRENGTH PER SQUARE FOOT™

We have a full line of Utility, Olympic and Specialty Benches.



FID Bench



Decline Bench



Lumbar Utility Bench

718065SS

Specialty Bench Line

# XL LADDER BENCH W/SPOTTER

## Specifications:

**FRAME:** 3" X 3" 11-Gauge Structural Steel Tubing

**WEIGHT:** 184 LBS

**DIMENSIONS:** 25" W x 20" H x 58" L (Flat)

25" W x 56" H x 55" L (Full Incline)

